

Cinema Mid-High-Very High Loudspeaker System User Manual

MHV-1090

10" (254mm) mid, coax high-very high compression driver

Introduction

The MHV-1090 system provides the mid, high, and very high frequency components of four-way screen channel loudspeaker system for high performance cinema applications. It was designed to operate with and be directly mounted on QSC's cinema low frequency enclosures.

The high frequency horn is a low-distortion waveguide providing highly articulate dialogue without the coloration associated with conventional horn loudspeakers. Both horns feature broad horizontal and vertical coverage to ensure audio integrity is delivered to every seat in the auditorium. The driver assemblies are mounted on an adjustable pan and tilt bracket that has an integral aiming sight, simplifying installation.

The MHV-1090 includes a driver protection and high-very high frequency crossover network to assure reliable operation. DC blocking capacitors protect against DC or low-frequency signals that could damage an unprotected driver. A 12 dB per octave crossover seamlessly blends the high and very high frequency elements when operated in tri-amp mode. Outboard processing is required to form the crossover between the low, mid, and high-very high frequency drivers.

Tri-amp or quad-amp operation is possible using a selector switch mounted on the **INPUTS** connection panel. The tri-amp setting provides a built-in passive crossover network between high and very high frequency drivers. Separate amplifiers and active crossovers are required for the low, mid, high-very high frequency channels. Quad-amp setting disables the internal high-very high frequency crossover and each driver is driven independently by its own amplifier and active crossover; one each required for the low, mid, high, and very high frequency drivers.

The MHV-1090 components come pre-assembled to reduce field assembly time. Three bolts are all that are required to secure the assembly to the top of a QSC low frequency enclosure.

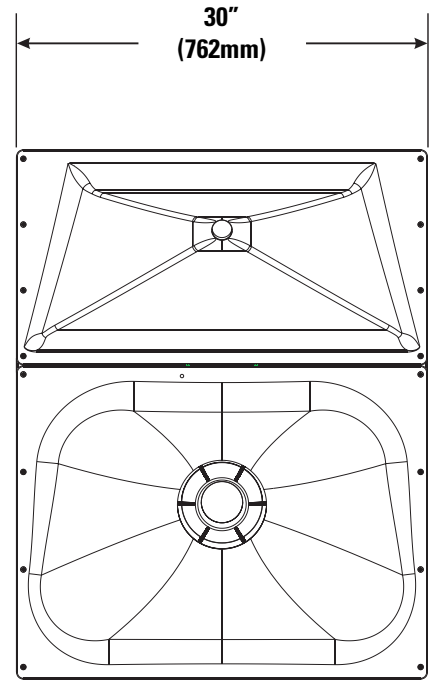
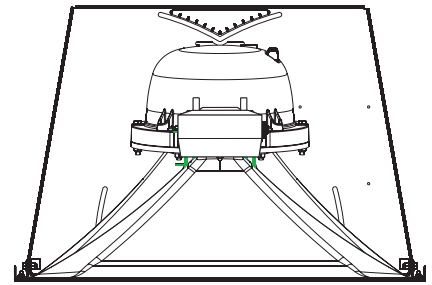

Install in accordance with QSC Audio Product's instructions and a licensed, professional engineer. Only use attachments, mounts, accessories, or brackets specified by QSC Audio Products, Inc. Refer all servicing to qualified personnel. Servicing is required when the apparatus has been damaged in any way.



WARNING! Before placing, installing, rigging, or suspending any speaker product, inspect all hardware, suspension, enclosures, transducers, brackets and associated equipment for damage. Any missing, corroded, deformed or non-load rated component could significantly reduce the strength of the installation, placement, or array. Any such condition severely reduces the safety of the installation and should be immediately corrected. Use only hardware which is rated for the loading conditions of the installation and any possible short-term unexpected overloading. Never exceed the rating of the hardware or equipment. Consult a licensed, professional engineer when any doubt or questions arise regarding a physical equipment installation.

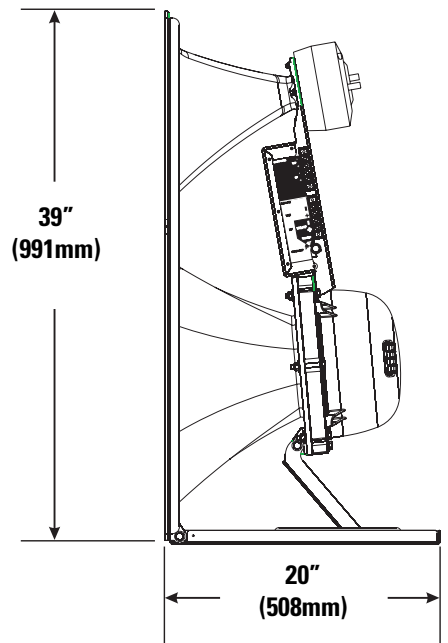

Mounting

Attaching to Low Frequency Enclosure

The MHV-1090 attaches to the top of QSC low frequency enclosures with three 0.75" long 5/16"-18 TPI bolts. ensure the use of lock washers on all bolts. The bolts and washers ship installed on the low frequency enclosure. We recommend the use of serviceable thread locking compound when installing the bolts to prevent loosening due to vibration. Do not fully tighten the mounting hardware before aiming in the horizontal plane (see below).

Aiming

Aim the horn in the horizontal plane (pan) before tightening the three bolts securing the MHV-1090 to the low frequency enclosure. Adjust the vertical tilt with the vertical adjustment bracket. The mid-high assembly is equipped with an aiming sight to assist in achieving desired coverage quickly and easily. For typical applications, the aim point should be the center seat in the back row of the auditorium. If the cinema screen has already been installed, a flashlight placed at the desired aiming point can be seen through the screen perforations in a darkened auditorium.

Where the sight holes are located:

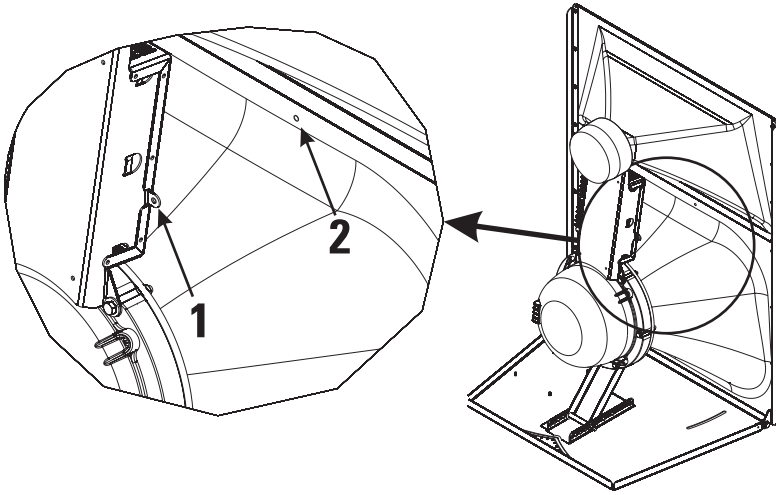

How to use the sights:

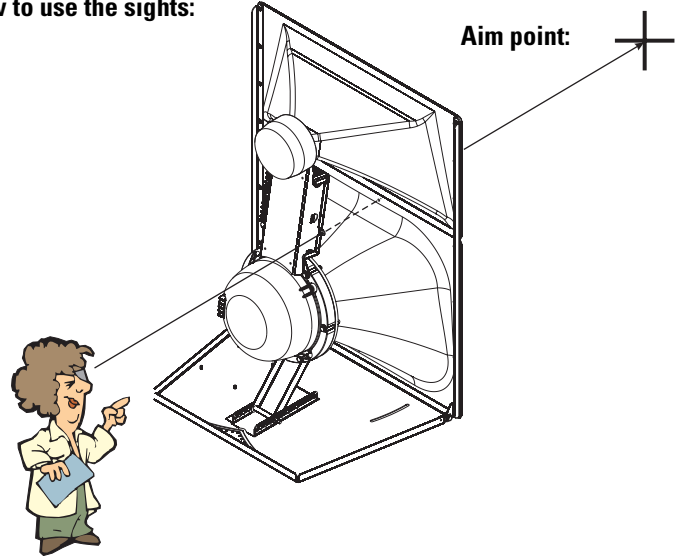

Settings and Connections

TRI-AMP / QUAD-AMP Operating Mode Selection

Set the operating mode selector switch to **TRI-AMP** or **QUAD-AMP**, depending on your screen channel signal processing and amplification set-up. The mid frequency driver will require connection to its rear cover terminals, regardless of mode selection. The low frequency driver will also require its own, separate connections. The only connection difference between tri-amp and quad-amp modes is in quad-amp mode, the very high frequency signal will require connection to the terminals labeled **VHF**.

TRI-AMP-When set to **TRI-AMP**, the MHV-1090 input panel connections accept high frequency/very high frequency signals on one set of inputs and uses an internal crossover network between the high and very high frequency drivers.

QUAD-AMP- When set to **QUAD-AMP**, the MHV-1090 input panel accepts separate high and very high frequency signals on two separate sets of inputs. The internal crossover network is bypassed and only the protective circuitry for the high frequency and very high frequency driver remains. Each of the driver's signals must have the appropriate upstream signal processing.



- Do not connect amplifiers directly to the high/very high frequency coaxial driver inputs!
- Always use the crossover INPUTS terminal strip for high and very high frequency input(s)
- The mid frequency driver and the low frequency enclosure are connected directly to their own separate amplifiers regardless of mode selector switch setting.

Mode selector switch set to TRI-AMP and the required HF/VHF connection:

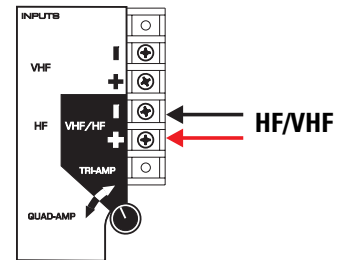

Mode selector switch set to QUAD-AMP and the required separate HF and VHF connections:

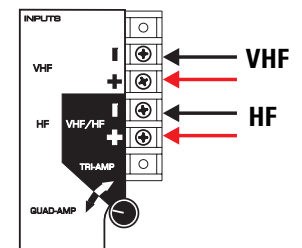

INPUTS Terminals

The MHV-1090 has barrier strip screw terminals that accept up to #10 AWG (5.3mm²) stranded loudspeaker wire. Observe proper polarity. Use the largest wire size and shortest wire length for the application.

OUTPUTS Terminals

The **OUTPUT** terminals are factory-connected to the high and very high frequency drivers. These terminals should **ONLY** be connected to their respective driver. Do not connect signals to these terminals as all protection and equalization circuitry will be bypassed. They are not for daisy chaining the signals to other drivers.



NOTE! Maintain proper loudspeaker connection polarity throughout the entire system for maximum performance. Do not apply full range signal to the MHV-1090! There is a high/very high frequency passive crossover for tri-amp mode only. There is no crossover connected when operating in quad-amp mode. All required signal processing must be done before the signal is applied to the loudspeaker. Do not connect any signal to the upper sets of OUTPUT terminals.

TRI-AMP mode connections- Ensure the mode selector switch is set to **TRI-AMP**, connect the low frequency signal to the low frequency enclosure; connect the mid frequency signal to the mid frequency driver; connect the high/very high frequency signal to the **VHF/HF** terminals on the **INPUTS** terminal strip.

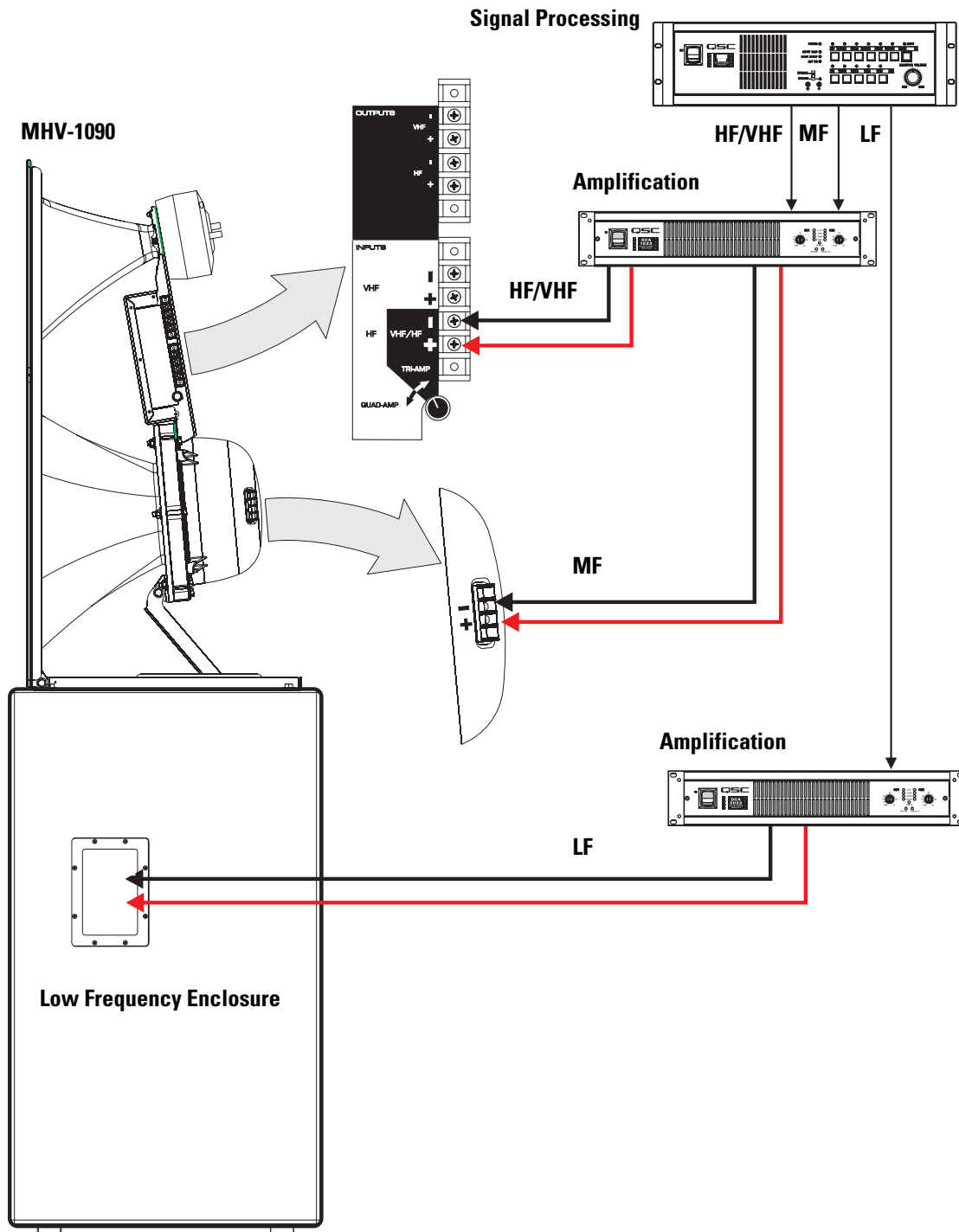

QUAD-AMP mode connections- Ensure the mode selector switch is set to **QUAD-AMP**, connect the low frequency signal to the low frequency enclosure; connect the mid frequency signal to the mid frequency driver; connect the high frequency signal to the **HF** terminals on the **INPUTS** terminal strip; connect the very high frequency signal to the **VHF** terminals on the **INPUTS** terminal strip.

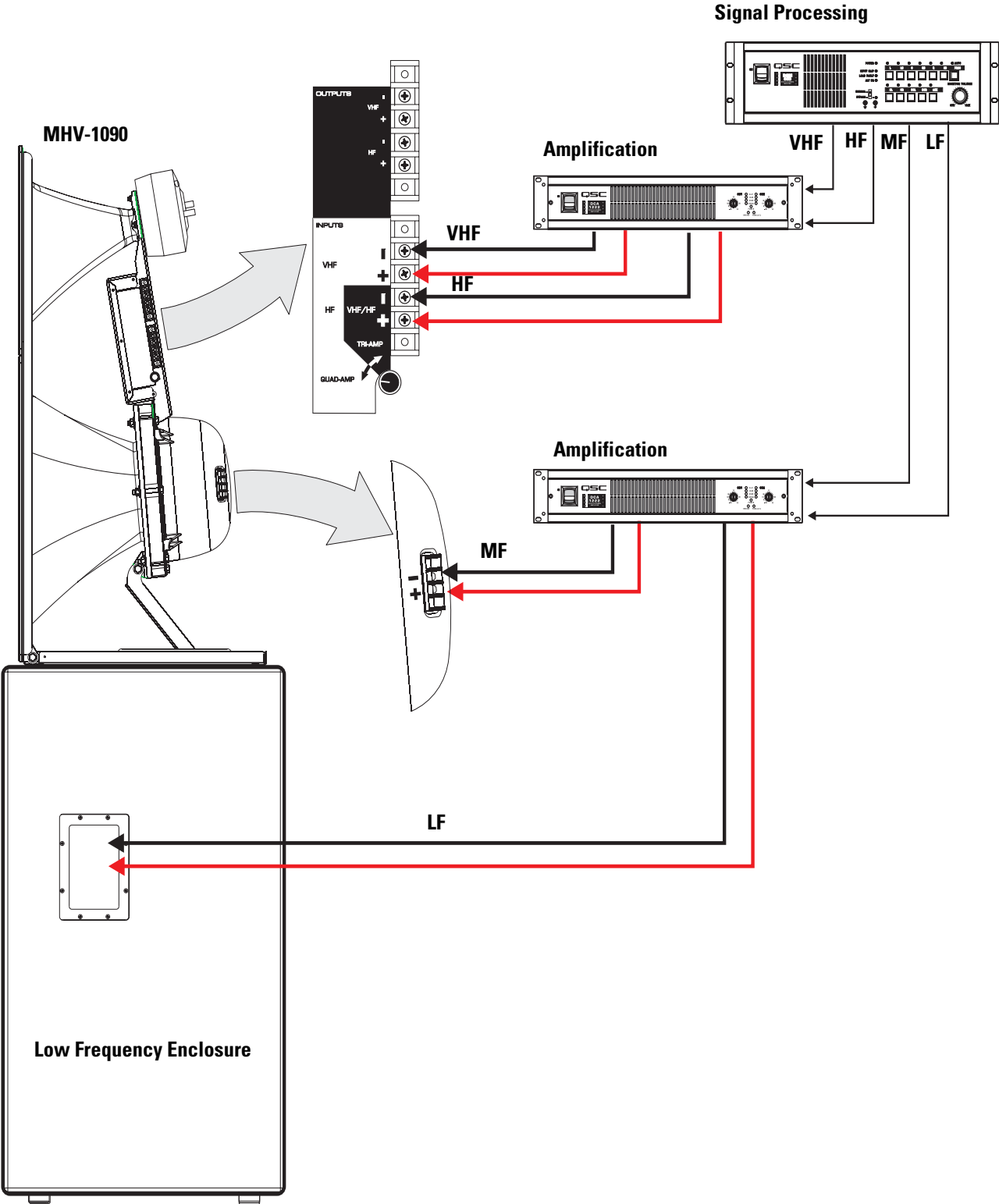

MHV-1090 Specifications (subject to change without notice)

Freq. Range	180 - 20k Hz (-6dB, full space)
Nominal Coverage	90° horizontal X +20 to -30° vertical (50° total, adjustable mount provides for vertical plane adjustments. The horizontal plane can be adjusted by altering mounting position on the low frequency enclosure before tightening bolts.
DI:	9 dB (400 to 16k Hz average)
Q:	8 (400 to 16k Hz average)
Max. Output:, calculated (1 meter, full space)	Mid frequency 135.5 dB SPL Tri-amp mode: high frequency/very high frequency 138 dB SPL Quad-amp mode: high frequency 138 dB SPL, very high frequency 135 dB SPL
Impedance:	Tri-amp mode: 8 ohms nominal, mid frequency and high/very high frequency Quad-amp mode: 8 ohms nominal, mid, high, and very high frequency
Maximum Input Power (AES method, 2 hours)	Mid frequency: 275 W Tri-amp mode: high/very high frequency 155 W (calculated, sum of high and very high frequency individual ratings) Quad-amp mode: high frequency 85 W, very high frequency 70 W
Sensitivity (1 Watt, 1 meter)	Mid frequency: 105 dB SPL Tri-amp mode: high/very high frequency 110 dB SPL Quad-amp mode: high frequency 110 dB SPL very high frequency 110 dB SPL
Crossover Frequencies	Tri-amp mode: mid frequency 250 Hz or higher, high/very frequency 1.7 kHz, both 24 dB/octave Quad-amp mode: mid frequency 250 Hz or higher, high frequency 1.7 kHz, very high frequency 6.0 kHz, all 24 dB/octave
Crossover Network	High frequency to very high frequency crossover at 7 kHz, 12 dB per octave, <i>only</i> in tri-amp mode. Quad-amp mode switch setting removes crossover circuit from signal path, but leaves DC blocking capacitors in circuit.
Connectors	Mid frequency driver: barrier strip screw terminals on mid frequency driver accept up to #10 AWG stranded wire. High frequency, very high frequency drivers: barrier strip screw terminals accept up to #10 AWG stranded wire Tri-amp mode connect high frequency/very high frequency program only to VHF/HF INPUTS terminals Quad-amp mode connect high frequency program to HF INPUTS terminals and connect very high frequency program to VHF INPUTS terminals.
Transducers	Mid frequency: 10" high efficiency mid-range, phase-ring loaded High frequency: 1.5" exit, 3.5" voice coil polyester diaphragm coaxial compression driver Very High frequency: 1.5" exit, 1.75" voice coil polyester diaphragm coaxial compression driver
Mounting Hardware:	Attaches to top of QSC's low frequency cinema enclosures using three 5/16"-18 x 3/4" long bolts (supplied on low frequency enclosure)
Size	39" high x 30" wide x 20" deep (991 x 762 x 508mm)
Weight	73.5 lb. (33 kg) net

MHV-1090 SPL vs. Frequency, Tri-amp, No Screen

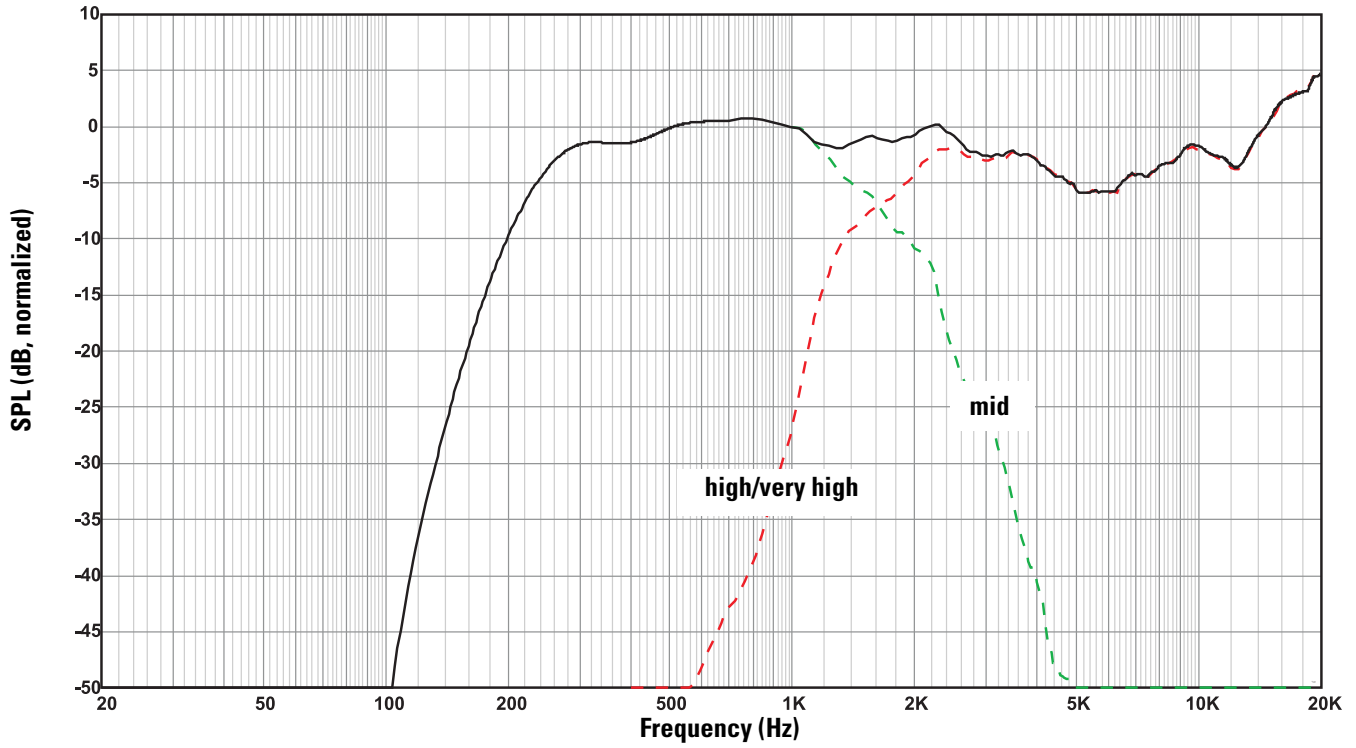

MHV-1090 SPL vs. Frequency, Quad-amp, No Screen

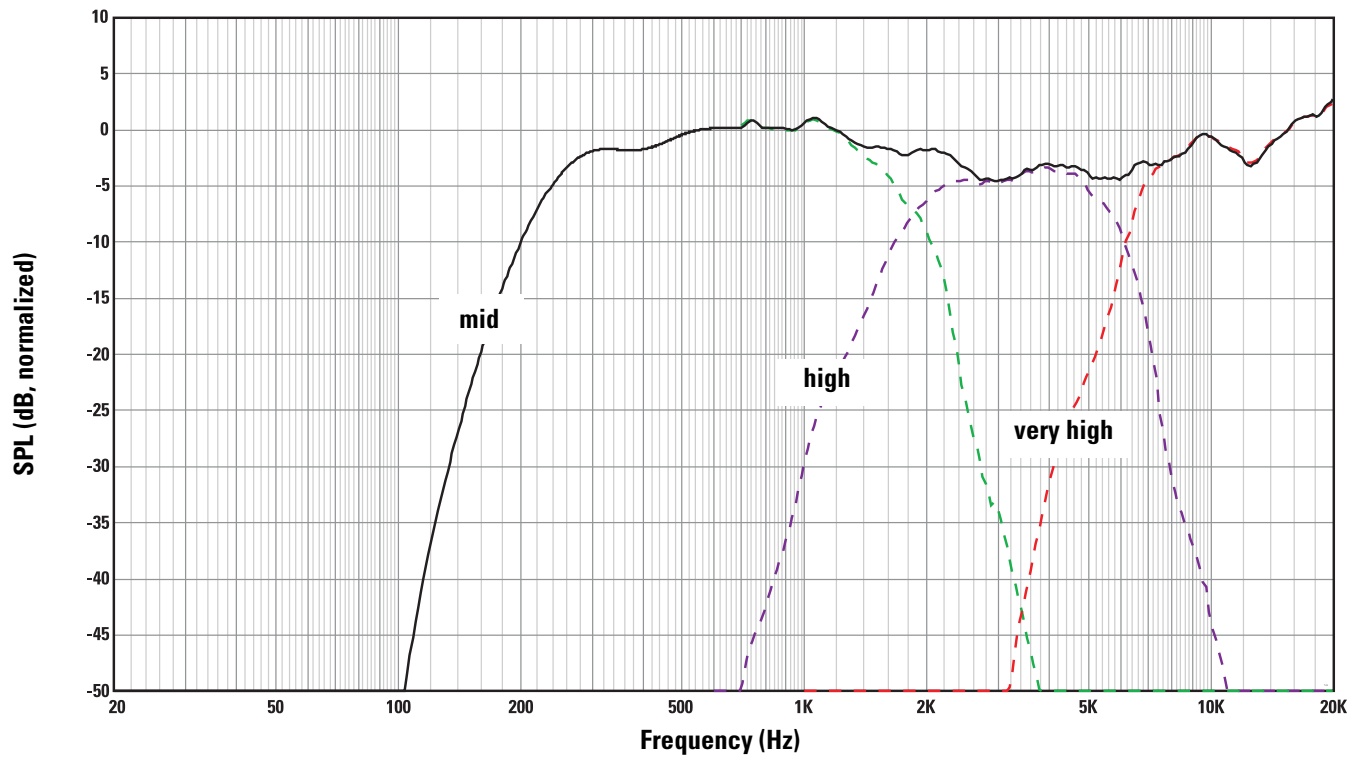

MHV-1090 SPL vs. Frequency, X-curve, Tri-amp, With and Without Screen

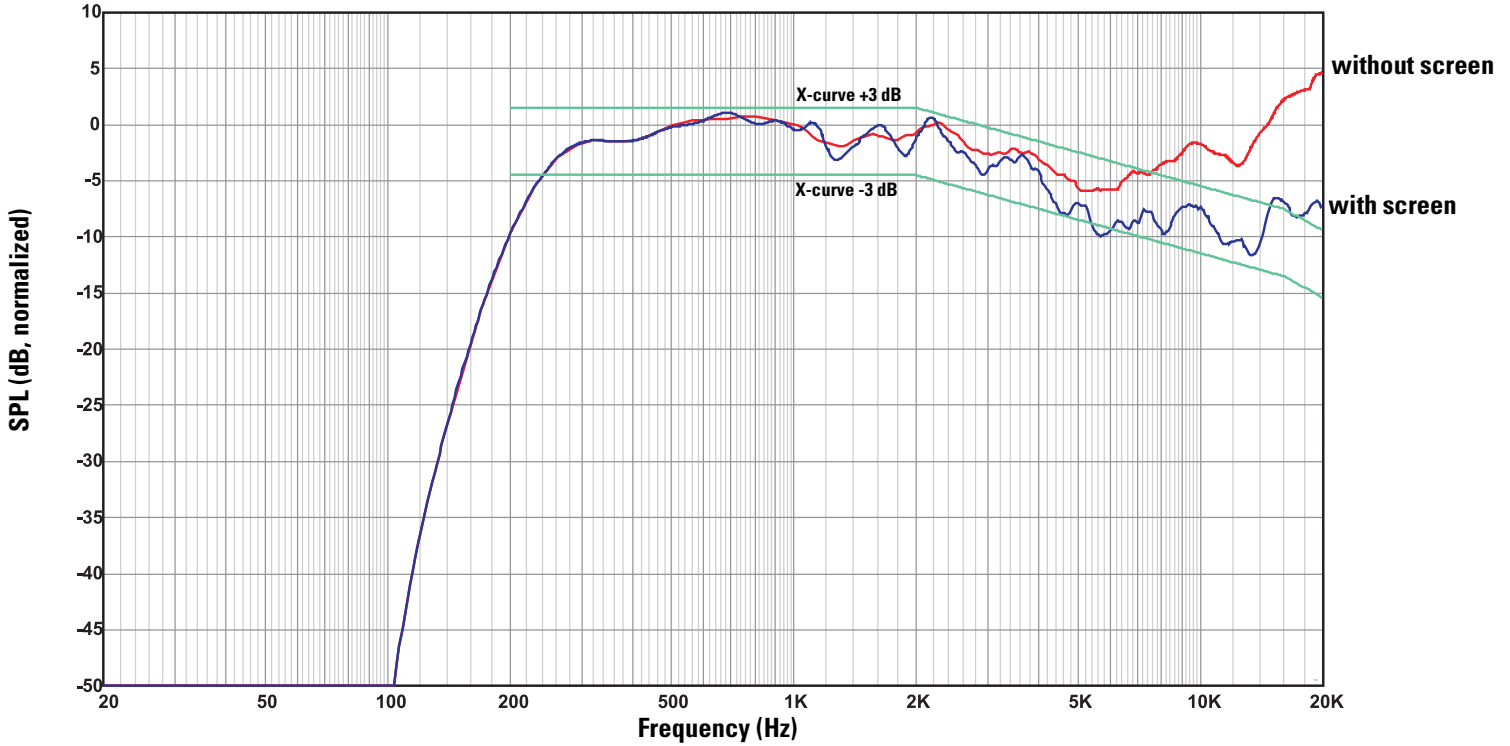

MHV-1090 SPL vs. Frequency, X-curve, Quad-amp, With and Without Screen

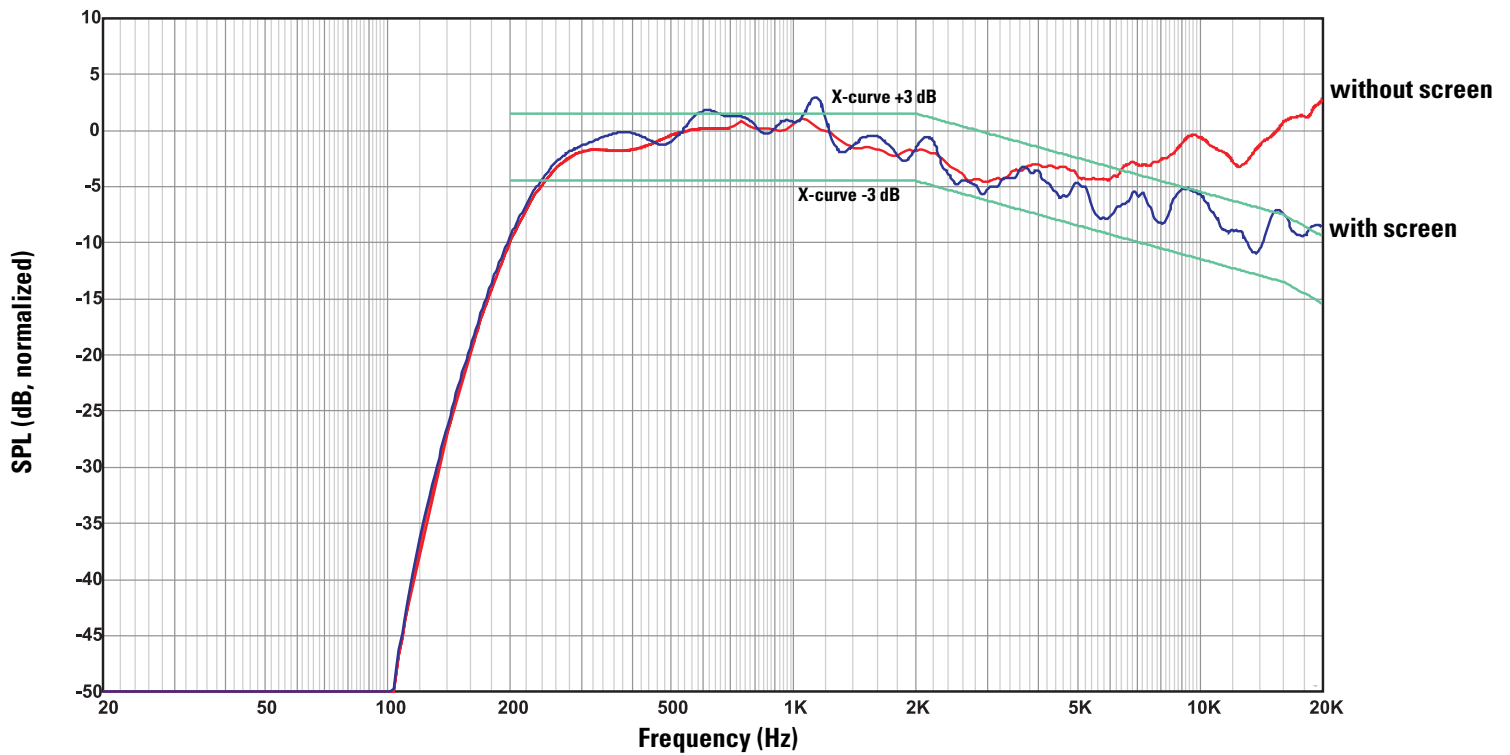

Warranty (USA only; other countries, see your dealer or distributor)

Disclaimer

QSC Audio Products, Inc. is not liable for any damage to amplifiers, or any other equipment that is caused by negligence or improper installation and/or use of this loudspeaker product.

QSC Audio Products 3 Year Limited Warranty

QSC Audio Products, Inc. ("QSC") guarantees its products to be free from defective material and / or workmanship for a period of three (3) years from date of sale, and will replace defective parts and repair malfunctioning products under this warranty when the defect occurs under normal installation and use - provided the unit is returned to our factory or one of our authorized service stations via pre-paid transportation with a copy of proof of purchase (i.e., sales receipt). This warranty provides that the examination of the return product must indicate, in our judgment, a manufacturing defect. This warranty does not extend to any product which has been subjected to misuse, neglect, accident, improper installation, or where the date code has been removed or defaced. QSC shall not be liable for incidental and/or consequential damages. This warranty gives you specific legal rights. This limited warranty is freely transferable during the term of the warranty period.

Customer may have additional rights, which vary from state to state.

In the event that this product was manufactured for export and sale outside of the United States or its territories, then this limited warranty shall not apply. Removal of the serial number on this product, or purchase of this product from an unauthorized dealer, will void this limited warranty. Periodically, this warranty is updated. To obtain the most recent version of QSC's warranty statement, please visit www.qscaudio.com. Contact us at 800-854-4079 or visit our website at www.qscaudio.com.

Contacting QSC Audio Products

Mailing address: QSC Audio Products, Inc.
1675 MacArthur Boulevard
Costa Mesa, CA 92626-1468 USA

Telephone Numbers:

Main Number (714) 754-6175

Sales & Marketing (714) 957-7100 or toll free (USA only) (800) 854-4079

Customer Service (714) 957-7150 or toll free (USA only) (800) 772-2834

Facsimile Numbers:

Sales & Marketing Fax (714) 754-6174

Customer Service Fax (714) 754-6173

World Wide Web: www.qscaudio.com

E-mail: info@qscaudio.com

service@qscaudio.com

