

The ALK-MD2 and ALK-MD3 Array Link Kits allow the user to quickly, easily and cost effectively assemble arrays of ModularDesign loudspeaker systems. The ALK-MD2 allows the construction of arrays that are two enclosures wide (Figure A) while the ALK-MD3 can be used to assemble three-wide arrays (Figure B). Arrays can be constructed using any trapezoidal enclosure full range or low-frequency model of the MD or MD Powered product range.

Arrays of up to six enclosures may be constructed by using multiple Array Link Kits to add a second "row" of two or three enclosures suspended below and from the first (Figure C).

Splay angles between adjacent enclosures can be adjusted in five degree increments from 45° to 75°. (Included angle between aiming axes) The design of the ALK-MD3 allows the splay angle between the center enclosure and those on the left and right to be adjusted independently.

Array Link Kits consist of a number of steel plates, four in the case of the ALK-MD2 and six for the ALK-MD3. These plates attach to the top and bottom of MD enclosures, making use of the existing suspension attachment points. Each plate has multiple mounting holes, all clearly labeled, that are used to set the splay angle between enclosures. Each kit includes all hardware required to assemble an array as well as three forged shoulder eyebolts to facilitate suspension of the assembled array.

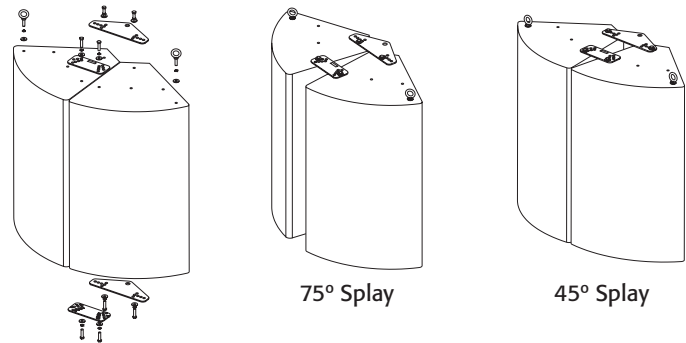

Figure A – 2-wide Arrays

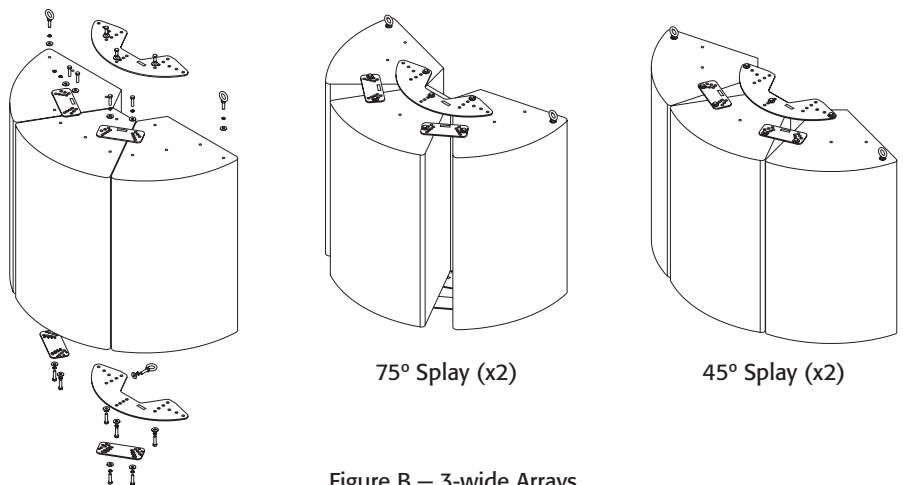

Figure B – 3-wide Arrays

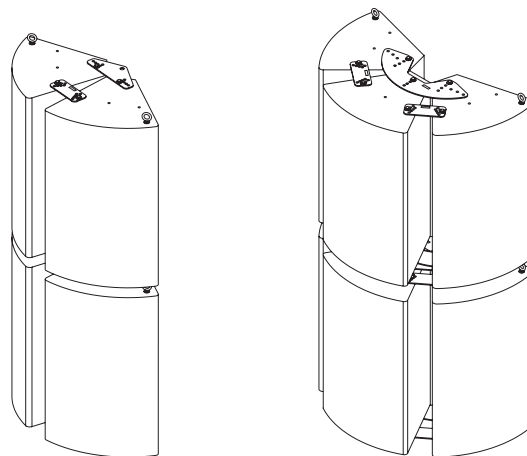

Figure C – 2-row Arrays