

Features

- Parallel outputs for feeding additional units
- 90° horizontal dispersion
- QuickMount bracket for fast, easy and secure installation
- High-power handling capability and rugged plywood enclosure optimized for digital soundtrack reproduction
- THX™ approved for professional cinema applications



Developed specifically for the unique requirements of professional motion picture playback, QSC extends its commitment to the cinema market with the introduction of the SR-26 Cinema Surround Loudspeaker. As a member of QSC’s DCS Digital Cinema Speaker Series, the SR-26 offers high-power handling, excellent sensitivity, and extended bass response in a very compact enclosure.

The SR-26 Cinema Surround Loudspeaker features two high-power, long-throw 6.5" low-frequency transducers coupled with a 1" titanium diaphragm compression driver. The system’s plywood enclosure features a 15° down angle baffle and Array Optimized Tuning (AOT) for optimum frequency response. The 150 watt continuous power rating and sophisticated crossover provides absolute reliability.

A 50° controlled vertical coverage provides for a better reach and more consistent sound pressure levels across the audience area.

The compact black enclosure with black grille blends into any theatre decor. A new QuickMount bracket design allows for fast, easy and secure installation. The loudspeaker half of the bracket comes pre-installed on each SR-26. The QuickMount wall bracket is purchased separately to allow shipment to the job site ahead of the loudspeakers. A traditional U-bracket is also available in lieu of the QuickMount bracket system.

Specifications

| | |
|---|--|
| Frequency Range ¹ | |
| -6 dB half space | 38 Hz – 20 kHz |
| -10 dB half space | 35 Hz – 20 Hz |
| Nominal Coverage | 90° horizontal x 50° vertical (averaged from 1 kHz to 10 kHz, -6 dB) |
| Directivity Index | 7.9 dB |
| Q | 6.2 |
| Maximum Output ² | |
| Calculated Peak at Rated Power | 121 dB |
| Calculated Continuous | 115 dB |
| Impedance | 8Ω nominal |
| Maximum Input Power ³ | |
| 100 hours of 6 db crest factor IEC 268 noise spectrum | 100 W RMS |
| 2 hours of 6 db crest factor pink noise, 50 Hz – 20 kHz, AES method | 150 W RMS |
| Recommended Amplifier Power | 300 W RMS maximum into 8Ω |
| Sensitivity 1 watt/1 meter, half space | 94 dB |
| Crossover Frequency | 2.6 kHz |
| Recommended Processing | Subsonic filter at 50 Hz as provided by QSC DCA amplifiers |
| Connectors | Barrier strip screw terminals accept up to #10 AWG stranded wire |
| Transducers | 2 x 6.5" long throw low-frequency transducers 1" titanium diaphragm compression driver on a CD horn |
| Enclosure | Plywood, baffle angle is 15° downward |
| Dimensions (HWD) | 23" x 14" x 11.75" (589 mm x 363 mm x 299 mm) |
| Weight – Net | 33 lbs (15 kg) |

1) All frequency ranges specified refer to measured free field response (half space, 2π).
 2) Calculated SPL at 1m, (half space, 2π), speaker operating at rated RMS power with pink noise within specified frequency range.
 3) Maximum input power tested in accordance with IEC 268-5 recommendations, 50 Hz – 20 kHz band limiting, 6 dB signal crest factor.

Top

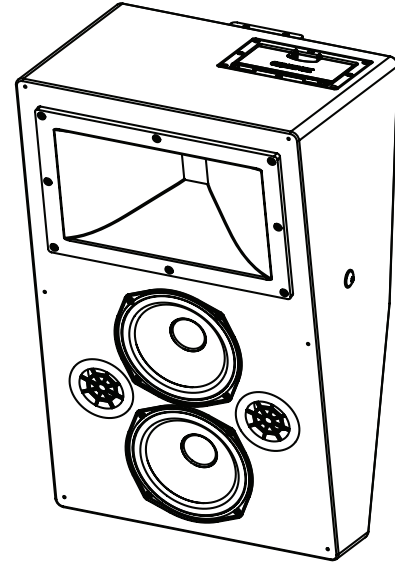
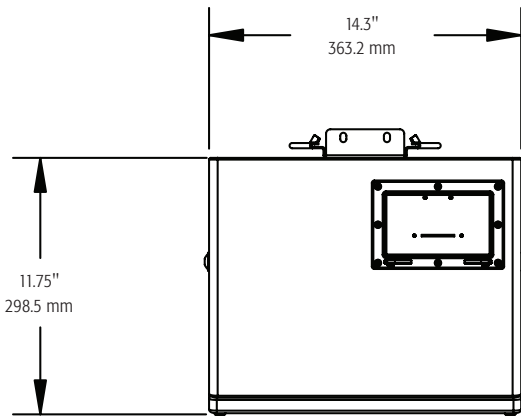

Front

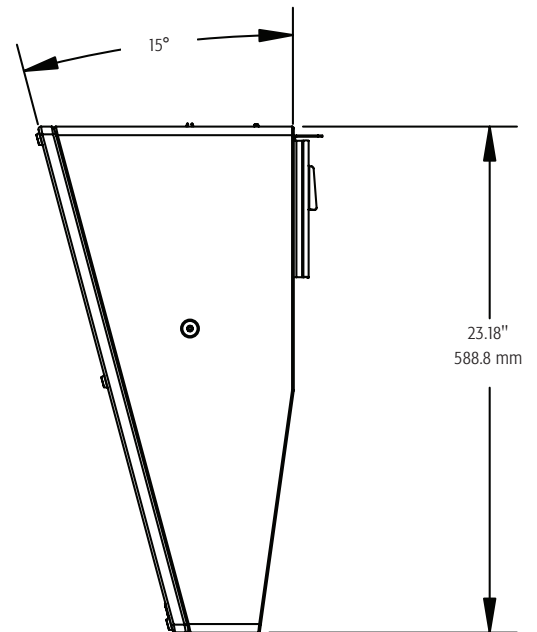
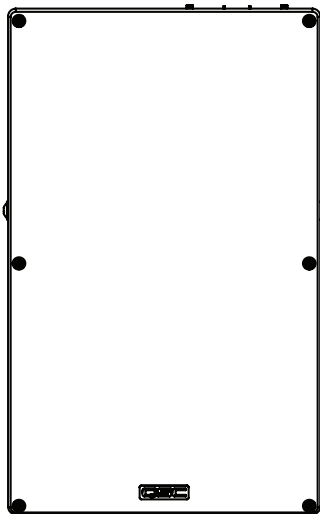

Side

Specifications subject to change without notice.

QSC, and the QSC logo are registered trademarks of QSC Audio Products, LLC in the U.S. Patent and Trademark office and other countries. THX is a trademark of THX Ltd. All other trademarks are the property of their respective owners. Patents may apply or be pending.

1675 MacArthur Boulevard • Costa Mesa, CA 92626 • Ph: 800/854-4079 or 714/957-7100 • Fax: 714/754-6174

SR-26 Spec Sheet - 06/20/08